

Firmware Features

- Wireless Data Communications Subsystem
- Embedded Bluetooth Serial Port Profile (SPP)
- Easy To Use AT Command Interface Using UART
- Remote Command And Control
- Multipoint / Piconet Capable
- Custom Firmware Available



33.2mm x 15.8 mm x 1.8 mm



Hardware Features

- CSR BlueCore™ 5 Chip Set
- Bluetooth v2.1+EDR Compliant
- Class 1 Radio, Range Typically Exceeds 150m
- High Speed Data Rate, Up To 3Mbps
- Programmable I/O pins - 20 Digital, 2 Analog
- 64 Mips DSP Co-Processor Onboard
- Two 16 Bit ADC Inputs up to 44 KHz Rate
- Two 16 Bit DAC Outputs up to 48 KHz Rate
- External Antenna Port
- USB, UART, SPI, I²S, PCM, and SPDIF Interfaces

Applications

- Bluetooth Serial Cable Replacement
- Bluetooth Data Cable Replacement
- Bluetooth Advertising
- Bluetooth RFID Tag Readers
- Bluetooth Digital Picture Frames
- Bluetooth Hand-Held Bar Code Readers
- Bluetooth Medical Monitoring
- Bluetooth Credit Card Readers
- Many, many, more . . .

Description

The KC-5100 data module is pre-engineered, pre-qualified, and highly tuned surface mount PCB module that provides fully embedded, ready to use Bluetooth wireless technology. Multi-surface pads provide both bottom pads for high volume reflow soldering and edge pads for low volume hand soldering.

The KC-5100 offers reprogrammable, embedded firmware for serial cable replacement deploying the Bluetooth Serial Port Profile (SPP). OEM specific parameters and settings can be easily loaded into these modules.

Our kcSerial embedded firmware provides an easy to use AT style command interface over UART. kcSerial is capable of storing OEM default settings, and is upgradable over UART. kcSerial also provides remote control capability, where our AT commands can be issued remotely from any other Bluetooth device using SPP. Custom firmware is available.

(This module is also available for audio applications, refer to our [KC-5190](#) -- Class 1, OEM Hi Power Bluetooth Audio Module.)

Physical Dimensions

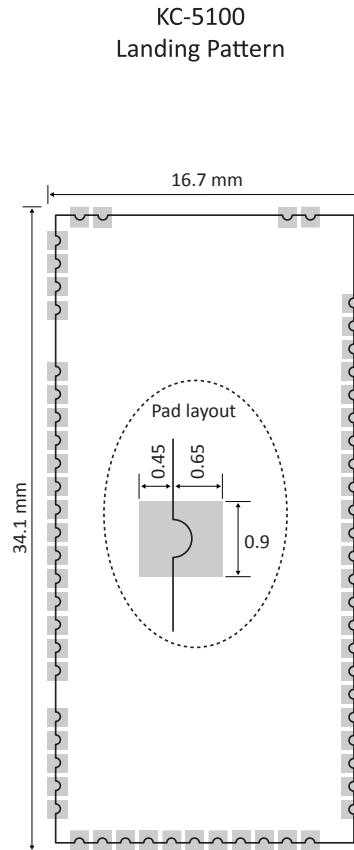
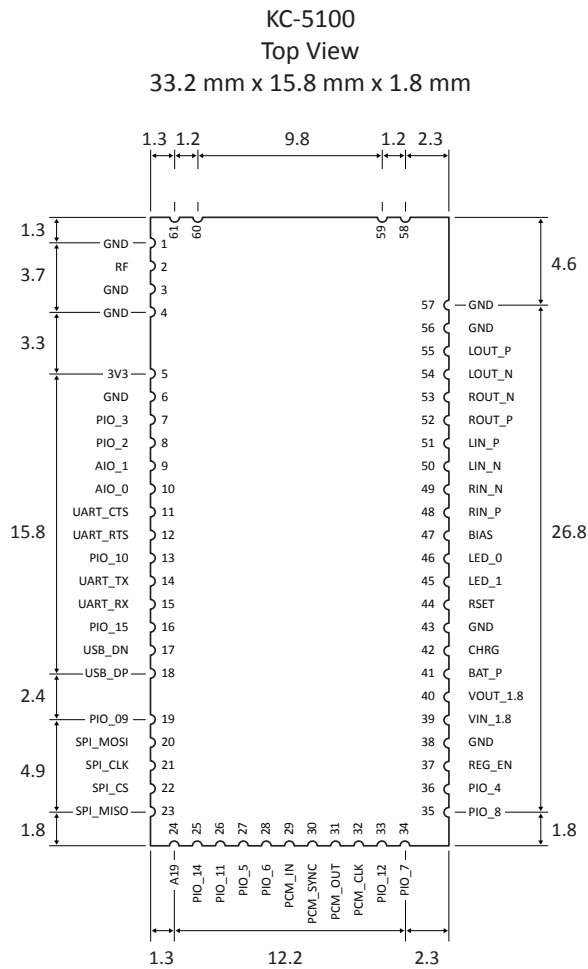

Pin Assignment

Pin	Function	Type	Description
1	GND	--	Ground
2	RF	I/O	RF input / output
3	GND	--	Ground
4	GND	--	Ground
5	VDD	I	3.3V input
6	GND	--	Ground
7	PIO_3	I/O	Programmable I/O line
8	PIO_2	I/O	Programmable I/O line
9	AIO_1	I/O	Analog Programmable I/O line [ADC] [DAC]
10	AIO_0	I/O	Analog Programmable I/O line [ADC] [DAC] [Clock]
11	UART_CTS	I	UART clear to send, active low
12	UART_RTS	O	UART request to send, active low
13	PIO_10	I/O	Programmable I/O line
14	UART_TX	I	UART data output, active low
15	UART_RX	O	UART data input, active low (idle status high)
16	PIO_15	I/O	Programmable I/O line
17	USB_DN	I/O	USB Data Negative
18	USB_DP	I/O	USB Data Positive
19	PIO_9	I/O	Programmable I/O line
20	SPI_MOSI	I	Synchronous serial interface data input
21	SPI_CLK	I	Synchronous serial interface Clock
22	SPI_CSB	I	Chip select for Synchronous Serial interface
23	SPI_MISO	O	Synchronous serial interface data output
24	A19	I	16Mbit flash memory High, 8Mbit flash memory Low
25	PIO_14	I/O	Programmable I/O line
26	PIO_11	I/O	Programmable I/O line
27	PIO_5	I/O	Programmable I/O line [RTS Bypass]
28	PIO_6	I/O	Programmable I/O line [CTS Bypass]
29	PCM_IN	I	Synchronous PCM data input [SPDIF IN] [I2S IN]
30	PCM_SYNC	I/O	Synchronous PCM data strobe [I2S WS]
31	PCM_OUT	O	Synchronous PCM data output [SPDIF OUT] [I2S OUT]
32	PCM_CLK	I/O	Synchronous PCM data clock [I2S SCK]
33	PIO_12	I/O	Programmable I/O line
34	PIO_7	I/O	Programmable I/O line [RX Bypass]
35	PIO_8	I/O	Programmable I/O line
36	PIO_4	I/O	Programmable I/O line [TX Bypass]
37	REG_EN	I	1V8 Regulator Enable

38	GND	--	Ground
39	VIN_1.8	I	1V8 Input Voltage
40	VOUT_1.8	O	1V8 Regulator Supply
41	BAT_P	I	Battery Positive Terminal
42	VDD_CHG	I	Internal Battery Charger Input
43	GND	--	Ground
44	RSET	I	Reset (Low Active)
45	LED_1	O	LED 1
46	LED_0	O	LED 0
47	MIC_BIAS	O	Bias Voltage
48	RIN_P	I	ADC Input Right Positive
49	RIN_N	I	ADC Input Right Negative
50	LIN_N	I	ADC Input Left Negative
51	LIN_P	I	ADC Input Left Positive
52	ROUT_P	O	DAC Output Right Positive
53	ROUT_N	O	DAC Output Right Negative
54	LOUT_N	O	DAC Output Left Negative
55	LOUT_P	O	DAC Output Left Positive
56	GND	--	Ground
57	GND	--	Ground
58	GND	--	Ground
59	GND	--	Ground
60	GND	--	Ground
61	GND	--	Ground

[Optional features in brackets]

Electrical Characteristics (Preliminary)

(Conditions VDD= 3.3V and 25 °C)

Absolute Maximum Ratings	Min	Max	Unit
Storage temperature range	-40	+85	°C
Supply voltage VDD	-0.4	3.6	Volts
Supply voltage BAT_P	-0.4	4.4	Volts
Supply voltage VDD_CHG	-0.4	6.5	Volts
Input current VDD_CHG	--	6	mA
Supply voltage REG_EN	-0.4	4.9	Volts
Input voltage for PIO, USB, UART	-0.4	3.6	Volts

Recommend Operating Conditions	Min	Typical	Max	Unit
Operating temperature range	-40	20	+85	°C
Supply voltage VDD	1.7	3.3	3.6	Volts
Supply voltage BAT_P	2.5	--	4.4	Volts
Supply voltage VDD_CHG	4.5	--	6.5	Volts
Supply voltage VIN_1.8	1.70	1.80	1.95	Volts
Supply voltage REG_EN	2.5	--	4.4	Volts
Input voltage for PIO, USB, UART	1.7	3.3	3.6	Volts

Current Consumption	Avg	Unit
Data Transmission @ 380kbps	40	mA
No Connection	2	mA
Peak current	60	mA

RF Characteristics	Min	Max	Unit
Carrier Frequency	2400	2483.5	MHz
Transmission Line	50	50	Ω
Transmission Power	0	20	dBm
Receive Sensitivity	-20	-90	dBm

Electrical Characteristics Cont. (Preliminary)

Programmable I/O Pins Operating Characteristics	Min	Typical	Max	Unit
V _{IL} Input Voltage Low Logic	-0.3	--	VDD x 0.25	Volts
V _{IH} Input Voltage High Logic	VDD x 0.625	--	VDD + 0.3	Volts
V _{OL} Output Voltage Low Logic	0	--	0.125	Volts
V _{OH} Output Voltage High Logic	VDD x 0.75	--	VDD	Volts
Output Current Low Logic	--	4.0	--	mA
Output Current High Logic	--	-4.0	--	mA
Input Leakage Current	-100	0	100	nA
Input Schmitt voltage	VDD x 0.25	--	VDD x 0.625	Volts
C _I Input Capacitance	1.0	--	5.0	pF
R _{puw} Weak pull up	500K	--	2M	Ω
R _{pdw} Weak pull down	500K	--	2M	Ω
R _{pus} Strong pull up	10K	--	50K	Ω
R _{pds} Strong pull down	10K	--	50K	Ω

Electrical Characteristics Cont. (Preliminary)

ADC Characteristics	Min	Typical	Max	Unit
Resolution	--	--	16	Bits
Sample Rate	8	--	44.1	kHz
SNR (@ 8kHz sampling)	--	79	--	dB
Digital Gain	-24	--	21.5	dB
Analog Gain	--	--	42	dB
Input full scale at maximum gain (differential)	--	4	--	mV rms
Input full scale at minimum gain (differential)	--	800	--	mV rms
3dB bandwidth	--	20	--	kHz
Microphone mode input impedance	--	6.0	--	Ω
THD+N (microphone input) @30mV rms input	--	0.04	--	%

DAC Characteristics	Min	Typical	Max	Unit
Resolution	--	--	16	Bits
Sample Rate	8	--	48	kHz
SNR (@ 8kHz sampling)	--	95	--	dB
Digital Gain	-24	--	21.5	dB
Analog Gain	0	--	-21	dB
Output voltage full-scale swing (differential)	--	750	--	mV rms
THD+N (@ 100kΩ load)	--	--	0.01	%

Firmware Interface

The KC-5100 offers our powerful kcSerial firmware interface using the UART, which provides an easy to use AT style text command interface. The firmware interface allows persistent storage of configuration parameters such as device name, default baud rate, security PIN, and automatic connection settings. Additionally kcSerial provides operational commands such as discovery, connections, security, read/write commands for I/O pins, and our remote command mode offering this same programming interface on the linked remote device as well. Please refer to our *kcSerial User Guide* for additional information.

kcSerial v2.4 AT Command List

Operation Commands

AT+KC Bond
 AT+KC Bypass
 AT+KC DisableBond
 AT+KC Discovery
 AT+KC DunConnect
 AT+KC DunDisconnect
 AT+KC ExitSniff
 AT+KC GPIOConfig
 AT+KC GPIORead
 AT+KC GPIOWrite
 AT+KC HCImode
 AT+KC RemoteCommand
 AT+KC RemoteCmdDisconnect
 AT+KC Reset
 AT+KC Sniff
 AT+KC SPPConnect
 AT+KC SPPDisconnect

Configuration Commands

AT+KC AllowBonding
 AT+KC Build
 AT+KC ChangeBaud
 AT+KC ChangeDefaultBaud
 AT+KC COD
 AT+KC DeepSleep
 AT+KC DeepSleepBlocking
 AT+KC DefaultLocalName
 AT+KC DefaultPinCode
 AT+KC DeleteSmartCable
 AT+KC DisableBond
 AT+KC DisconnectNotice
 AT+KC EnableBond
 AT+KC EraseBondTable
 AT+KC FactoryReset
 AT+KC Help
 AT+KC HostEvent
 AT+KC IndicatorActivity
 AT+KC IndicatorCPU
 AT+KC IndicatorConnection
 AT+KC LocalName
 AT+KC SaveSettings
 AT+KC Security
 AT+KC ShowSettings
 AT+KC SmartCableSetup

AT+KC SmartCableReset
 AT+KC UpdateInquiryScan
 AT+KC UpdatePageScan
 AT+KC Verbose
 AT+KC Version

Hardware Interfaces

Battery Input and Charger

The module has built in voltage regulators, and can be operated directly from a Lithium battery. Additionally, the module has a built in battery charger.

UART Interface

It is highly recommended that UART pins are available for external connection (DB-9 connector or test points) to allow for firmware updates or reinstallation.

The UART is compatible with the 16450 industry standard. Four signals are provided with the UART interface. The TX and RX pins are used for data while the CTS and RTS pins are used for flow control. Maximum UART data rate is 3Mbits/s. The UART pins operate at TTL voltage level and must be translated to higher RS-232 voltage levels for communicating with PC hosts. A Maxim 3225 series or similar translator is recommend.

UART Bypass Interface

A UART bypass feature is available where the UART signals are passed through to PIO [4,5,6,7]. An external processor is required to issue a command that enables the bypass mode. The module will be in Deep Sleep while in bypass mode, and requires an external reset to resume normal operation.

SPI Interface

The SPI pins are available for firmware loading and CSR Software Development Kit programming.

USB, I²S, SPDIF, PCM Interfaces

These interfaces are all available for custom applications. Drivers and specific behaviour must be custom programmed.

PIO Interface Pins

PIO pins are read and write enabled via kcSerial commands. Inputs can be configured for weak pull-up, weak pull-down, strong pull-up, strong pull-down. Voltage input tolerance and output level is directly related to the VDD level.

AIO Interface Pins

AIO_0 and AIO_1 can be enabled for analog input or output, providing a 10 bit ADC or a 8 bit DAC. samples at rates up to 700 samples/sec. Analog mode is 1.8V logic. The AIO_0 pin can be configured for a clock output signal of 2, 6, 8, 12, 16, 24, 32, 48, or 64 MHz. AIO pin usage must be custom programmed by KC Wirefree for desired operation.

LED Interface Pins

Two open-drain LED output pins are available. The LED's need a positive voltage supply, and a current limiting resistor.

Reset

The module will reset with a low signal for 5ms.

Auxiliary 64 MIPS Processor

This high speed co-processor is programmable with the CSR BlueLab Software Development Kit using Assembly Language only. Typically used for audio applications, it is suitable as a powerful, low cost, low power, general purpose digital signal processor.

Hardware Design

KC Wirefree modules provide UART, USB, SPI, and PIO hardware interfaces. This section illustrates a typical implementation, and does not consider all cases. Our engineers are available to review designs and answer any other design questions. Contact our engineering department directly by email: tech@kcwirefree.com

Application Notes

- Power supply to module should have less than 10mVrms noise between 0-10MHz, and spikes should be minimal.
- Regulator should have a fast response time < 20 μ s. It is essential that the power rail recover quickly.
- 10 μ F or larger capacitor filter for VDD input.
- All unused pins should be unconnected.
- The area around the module should be free of any ground planes, power planes, trace routings, or metal. Minimum clearance is 5mm, but additional clearance allows improved range and throughput.
- Recommend connections for all four UART pins (DB-9 connector or test points) for firmware updates.
- Recommend test points for all four SPI pins, for emergency factory debugging and firmware reloading.
- Do not clean modules with Alcohol which can interact with no-clean solder flux residue.
- Do not use ultra sonic cleaning, which may cause internal interconnect damage.

Example Schematics

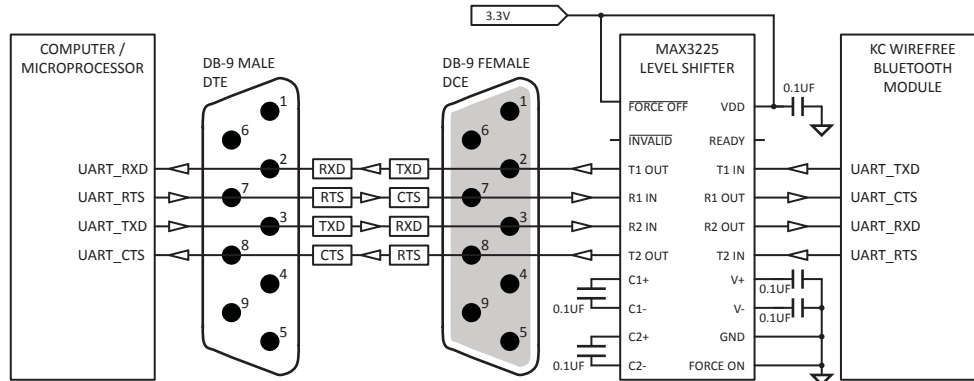

UART connection with level shifting

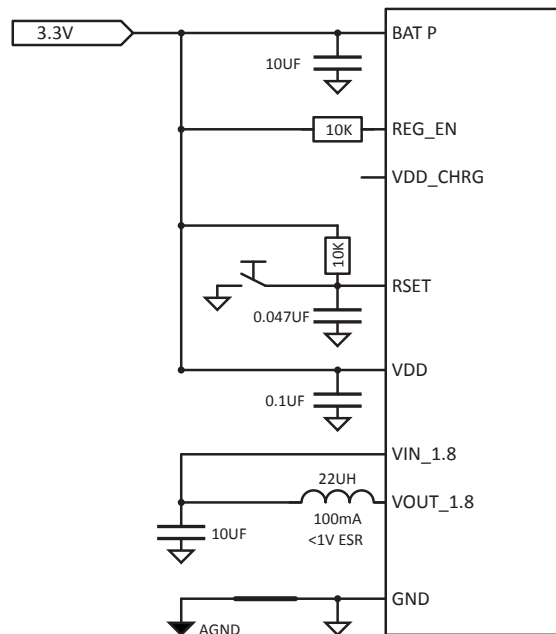

Regulated 3.3v power supply connection

Datasheet Version

April 07, 2009

Revisions	Changes
March 30, 2009	Preliminary release
April 07, 2009	Updated tables, schematics, formatting

Ordering Information

Product Series	KC-5100
Product Version	1.0
Country of Manufacture	Taiwan
Order Part Number	Description
KC-5100	OEM Hi Power Bluetooth Data Module
KC-5100-FW	OEM Hi Power Bluetooth Module, w/Custom Firmware

Contact Information

KC Wirefree
 2640 W Medtronic Way
 Tempe, Arizona 85281

Office

(602) 386-2640
 (602) 386-2642

Phone
 Fax

www.kcwirefree.com
 tech@kcwirefree.com

Website
 Technical Support